

## Bridge Engineering



(Individual Or Team; Competitive; On-Site Testing)

### DESCRIPTION:

The purpose of this contest is to provide an opportunity for students to demonstrate their ability to design and construct a bridge capable of withstanding as great a compressive load as possible. With assigned span and width specifications, bridges will be stressed to their failure point. A team may consist of no more than two members.

### General Rules And Regulations Checklist:

1. The student entering the bridge must provide the following:
  - a. A full size set of elevation drawings of the proposed bridge.
  - b. A bridge corresponding to the set of drawings for testing.
2. The bridge must be constructed from materials specified (3/32" x 3/32" basswood). Any common bonding materials (glue) may be used. No other materials may be used.
3. The bridge must be symmetrical in all respect to a vertical axis through its geometric center.
4. Outriggers are not allowed. Outriggers are any structures added to a bridge to mainly satisfy dimensional constraints.
5. The bridge must be designed around a horizontal "roadway" with a minimum width of **60 mm** and a **minimum length of 300 mm and a maximum length of 325 mm.**
6. The top of the roadway must be at a height no greater than **16 mm** above grade. Grade is defined as the level of the top surface of the test support.
7. The *bridge is not required* to but may have a substructure or super structure; the bridge design is left completely to the designer. If a substructure is used it may not exceed 274 mm and must be centered on the roadway.
8. Note that the roadway/roadbed need not be as long as the bridge.

The bridge must be designed so that a 40 mm x 60 mm x 12.5 mm "vehicle" can pass through the bridge.
9. Bridge mass cannot be greater than 45 grams.
10. Bridge length cannot exceed 325 mm.
11. Roadway length cannot exceed 325 mm.
12. Roadway height/thickness cannot exceed **16 mm above grade.**
13. There is no limit on overall bridge height, nor is the bridge required to, but may have a sub structure or super structure.
14. *Lengthwise laminations of more than 2 pieces of basswood are not allowed.*

Lengthwise is defined as the length of the beams.
15. No coating of surfaces with glue will be allowed, glue only allowed at joints.

### CRITERIA FOR JUDGING:

The test load will be applied to the bridge by means of a 12 mm thick x 40 mm wide x 60 mm long plate placed on the roadway with its edges parallel to the sides of the bridge. The load plate will be located at the center of the bridge, or at some integral multiple of 3.5 cm from the bridge center along the roadway axis.

During testing the bridge abutments (blocks the bridge will set upon during testing) will be set *275 mm apart*, Refer to example below.

*Any Rules or Regulation Violation = -25% For Each Violation In Bridge Efficiency*

*More than 2 Violations Will Result In Total Disqualification*

Weight will be applied to the loading plate until the bridge fails.

Bridge efficiency will be determined by this formula:

$$\text{Bridge Efficiency} = \frac{\text{Weight Supported in Gram}}{\text{Weight of Bridge in Gram}}$$

Awards in Levels II and I.



## Bridge Engineering Evaluation Sheet

Name: \_\_\_\_\_ Level: I or II (circle one) School: \_\_\_\_\_

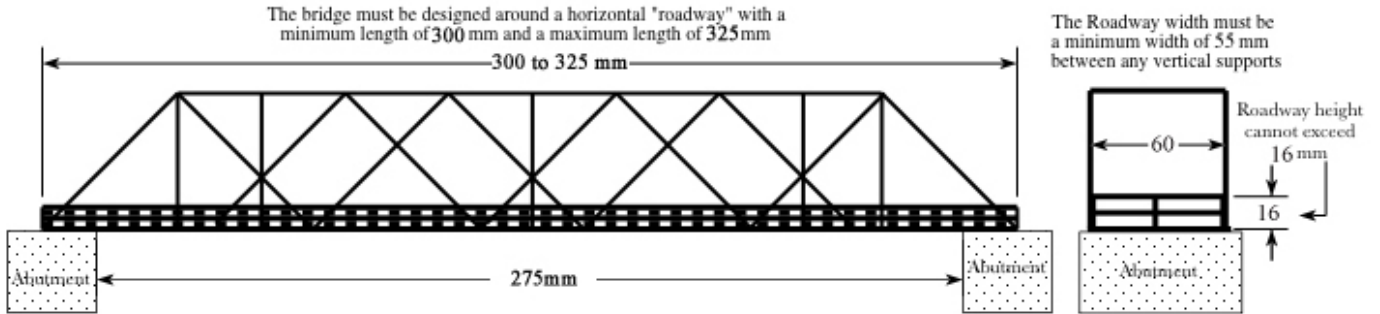

### Rules And Regulations Checklist

Checklist of Items / Requirements:

The Student Entering The Bridge Must Provide The Following:

- \_\_\_\_\_ A. Full Size Set of Elevation Drawings of The Proposed Bridge.
- \_\_\_\_\_ B. Bridge Corresponding To The Set of Drawings For Testing.

Bridge Specifications

- \_\_\_\_\_ 1. Minimum Roadway Width Of 60 mm (between any structure above the roadway)
- \_\_\_\_\_ 2. Minimum (Bridge) Length of 300 mm and Maximum Length of 325 mm
- \_\_\_\_\_ 3. Maximum Roadway Height of 16 mm
- \_\_\_\_\_ 4. Maximum Bridge Mass of 45 Grams
- \_\_\_\_\_ 5. Maximum Lengthwise Laminations of beams (No more than 2)  
Defined As Length of Beam.
- \_\_\_\_\_ 7. The Bridge allows a 40 mm X 60mm X 12 mm Vehicle To Pass Through The Bridge Roadway

### Judge Scoring:

Bridge Efficiency Will Be Determined By The Formula above:

\_\_\_\_\_ **Bridge Weight In Grams**

\_\_\_\_\_ **Bridge Failure Weight In Grams**

$$\text{Bridge Efficiency} = \frac{\text{Weight Supported in Gram}}{\text{Weight of Bridge in Gram}}$$

\_\_\_\_\_ **Total Score - Bridge Efficiency %**

\_\_\_\_\_ **Any Rules And Regulation Checklist Violation**  
(-25% Of Bridge Efficiency Per Violation)

\_\_\_\_\_ **Final Score**

\_\_\_\_\_ **Entrant Ranking**